



Thomas Research Products

Innovative & Energy Saving Lighting Controls

ESP-AUTO Universal Voltage Quartz Restrike System

The ESP-AUTO is a universal voltage (120-277V) control that incorporates a current sense circuit that automatically lights a quartz lamp when the main HID lamp is extinguished.

Features

- ◆ For electronic ballasts from 120V-277V Universal Voltage Input
- ◆ Compact and simple to wire
- ◆ Measures the current drawn by the HID lamp circuit rather than output voltage across the circuit allowing use with virtually any type of lamp or ballast circuit
- ◆ Operates on HID circuits from 39-450 watts
- ◆ Operates auxiliary lamps up to 250W
- ◆ High temperature, flameproof plastic enclosure, 90°C maximum surface temp rating
- ◆ Non arcing switches allow the ESP-AUTO to be used in Class 1, Division II vapor tight fixtures
- ◆ Can be wired directly to emergency generator power
- ◆ Individual Carton (-IC) includes mounting bracket and wiring instructions for Distributors and End-Users
- ◆ Not to be used to drive a Fluorescent standby source, use ASP-AUTO-T for that application
- ◆ Patents Pending

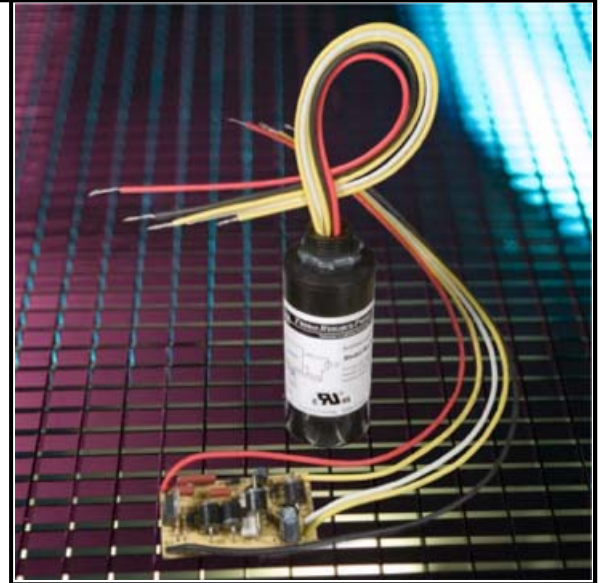

Dimensions

Body: 12" leads, stripped 0.63"

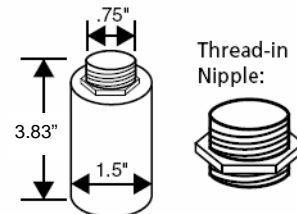

Wiring

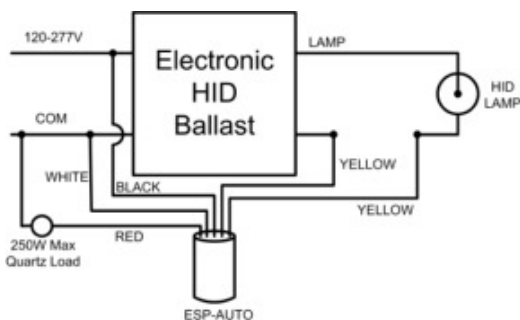

01-06-10